

Features

- Allows branching off the daisy chain riser bus reaching to stairwells or a second riser, eliminating the hassle and cost of looping wire
- Can be used to extend the distance of long wire runs between Remotes
- Power & RS-485 short circuit protected
- Supervised and monitored by the Master Command Panel
- Mounted in a TC1 or B-5 size enclosure

Isolator Module

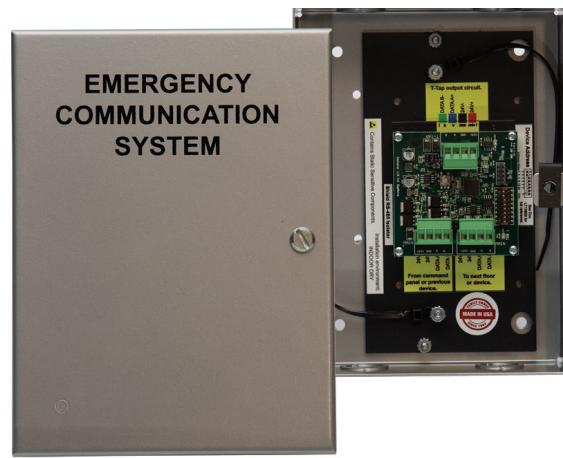

When your installation deals with multiple risers or cables that are not well-suited for digital communication, these modules simplify your cable runs to cut down on cost and improve Shield30 system integrity.

Specifications

Isolator shall allow for protection and t-tap of the RS-485 communication bus. The "Riser" side of the board will have two connectors for "in" and "out". The communications and power on these connectors shall be protected from short circuit so that a short after the "out" connector will not affect power or communications before the "in" connector. The t-tap side of the board shall form a new isolated branch for the communication bus. Any short on the t-tap bus will be isolated from the riser bus. Wire length calculations shall start at zero from this new communication branch. The Isolator shall be a smart device on the communication bus. It requires an address, and count as one of the maximum of 32 devices. The Isolator will be monitored by the system; if an Isolator goes off line it will be reported as a trouble. The Isolator shall run off the 24VDC system power, therefore may be put in-line anywhere on the circuit.

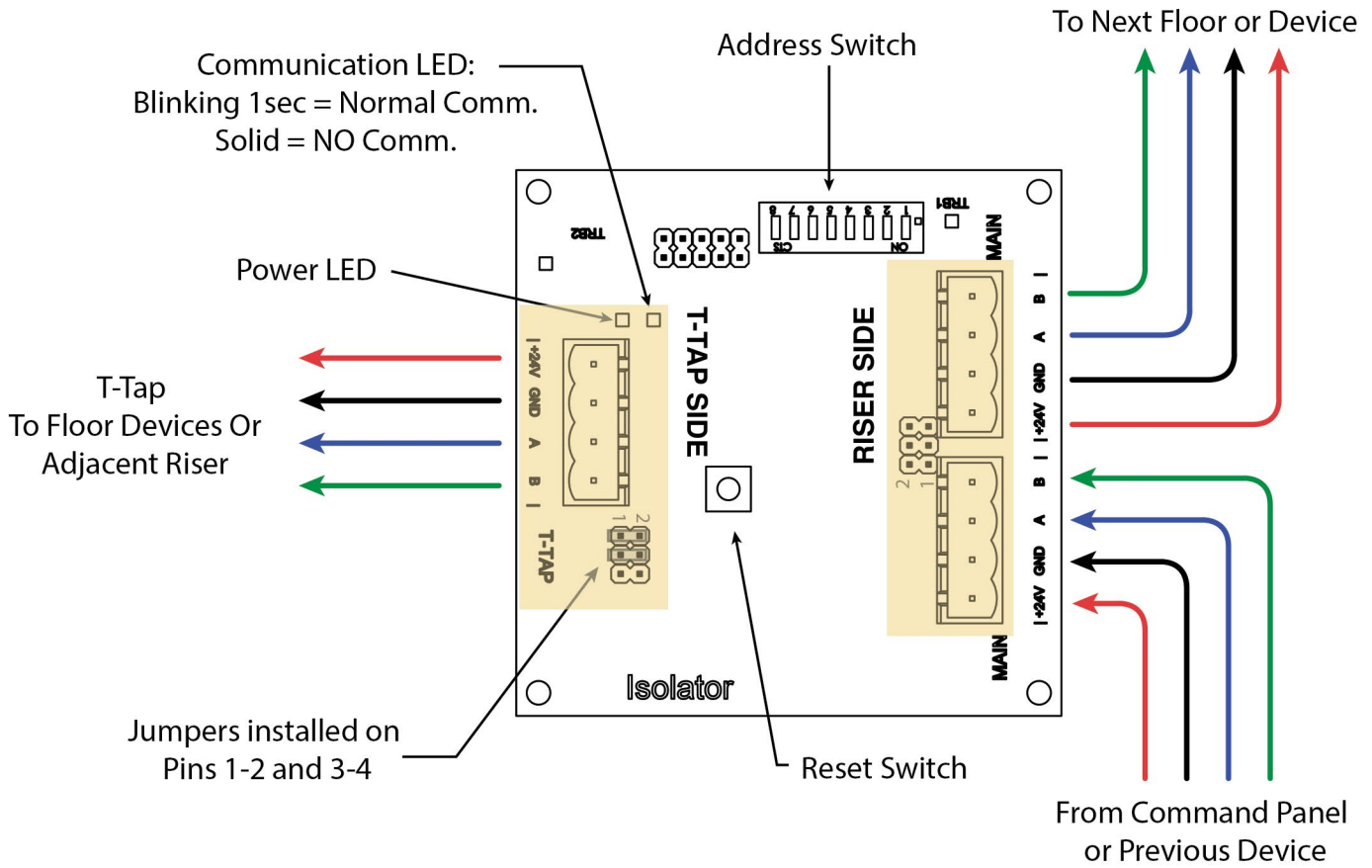

Ordering Information

P/N#	Description
SISOV	Isolator Module in Silver Enclosure